

## CONVENIENCE OUTLETS

### S830 Convenience Outlet

- UL Listed, 120V, 15A
- Sets include all items shown in drawings. Sets shipped in bulk.
- Standard Packed 100 to a carton.
- Product Specifications listed below.

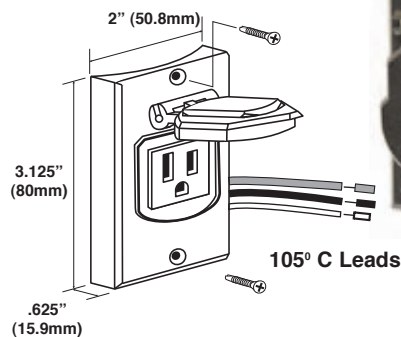
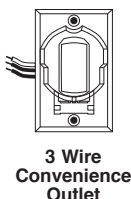

Style	Colors	Height	Width	Deep	Lead Length
S830BC	Black	3.125"	2"	.625"	7.25"
S830PC	White	3.125"	2"	.625"	7.25"

### 15-040 Grounded Convenience Outlet

- UL Listed, 125V, 15A
- Standard Packed 500 to a carton.
- Product Specifications listed below.

Style	Colors	Height	Width	Deep	Lead Length
15-040BK	Black	1"	1"	.625"	6.0"
15-040WH	White	1"	1"	.625"	6.0"



## DUSK TO DAWN SWITCHES

### PC-08 Incandescent & Fluorescent Dusk To Dawn Switch

- **Maximum Wattage:** Incandescent - 120V, Up to 300 Watts  
GU24/Fluorescent - 120V, Up to 39 Watts
- Can be used with Electronic and Magnetic Ballast
- Electronic Circuit with Mechanical Switching Relay
- UR, CUR Recognized
- Standard Packed 250 to a carton

Style	Colors	Height	Width	Length	Lead Length
PC-08	Black	1.3"	.67"	1.45"	14"

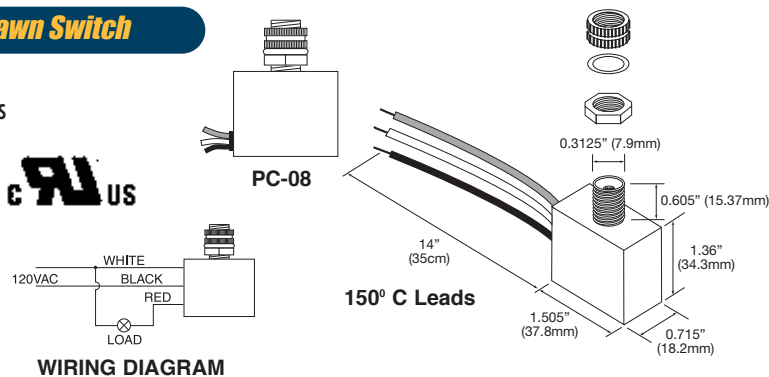

### 03-003 Dusk To Dawn Switch Swivel Hood and Base

- Fully adjustable two piece cover helps to eliminate strobing caused by light reflected off nearby surfaces
- Fits Inter-Global PC-08 Dusk to Dawn Switch
- Standard Packed 500 to a carton

Style	Colors
03-003	Black
03-003WHT	White

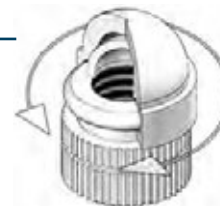
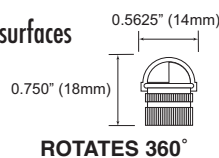

### S822BC Incandescent Dusk To Dawn Switch

- **Maximum Wattage:** Incandescent - 120V, Up to 300 Watts
- Can be used with Electronic and Magnetic Ballast
- Electronic Circuit W/Mechanical Switching Relay
- UL, CUL Listed
- Standard Packed 100 to a carton

Style	Colors	Height	Width	Length	Lead Length
S822BC	Black	1.687"	1.06"	2"	8"

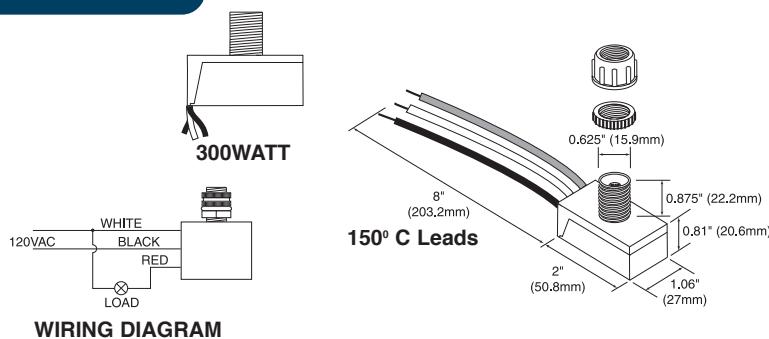

## DUSK TO DAWN SWITCHES (CONTINUED)

### PTOSW2 Incandescent Dusk To Dawn Switch

- **Maximum Wattage:** 120V, Up to 60 Watts
- Electronic Circuit
- UL Recognized Component Photo Electric Switch
- Standard Packed 500 to a carton
- **Not for use with Fluorescent Lighting**

Style	Colors	Height	Width	Length	Lead Length
PTOSW2	Black	1.06"	1"	1.875"	12.5/8.5"



03-024 (Clear)  
sold seperately



K005BR  
sold seperately

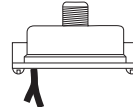

PTOSW2

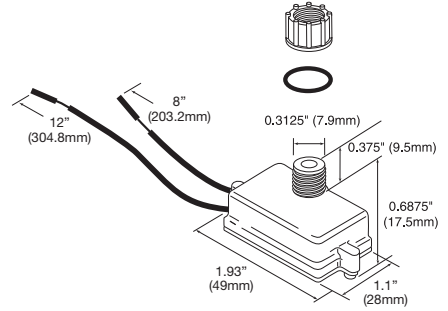

150° C Leads

### PTOSW4 Magnetic Fluorescent Dusk To Dawn Switch

- **Maximum Wattage:** 120V, Up to 13 Watts
- For use with Magnetic Fluorescent Ballast Only
- Electronic Circuit
- UL Recognized Component Photo Electric Switch
- Standard Packed 500 to a carton

Style	Colors	Height	Width	Length	Lead Length
PTOSW4	Black	1.06"	1"	1.875"	12.5/8.5"



03-024 (Clear)  
sold seperately



K005BR  
sold seperately

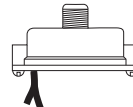

PTOSW4

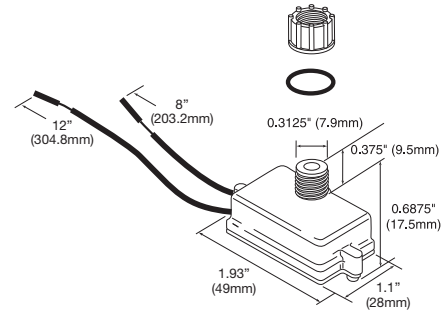

150° C Leads

### PTOSW5 Magnetic Fluorescent Dusk To Dawn Switch

- **Maximum Wattage:** 120V, Up to 13 Watts
- For use with Magnetic Fluorescent Ballast Only
- Electronic Circuit
- UL Recognized Component Photo Electric Switch
- Standard Packed 500 to a carton

Style	Colors	Height	Width	Length	Lead Length
PTOSW5	Black	1.375"	.75"	1.875"	12.5/9"



03-024 (Clear)  
sold seperately



K005BR  
sold seperately

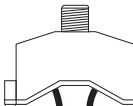

PTOSW5

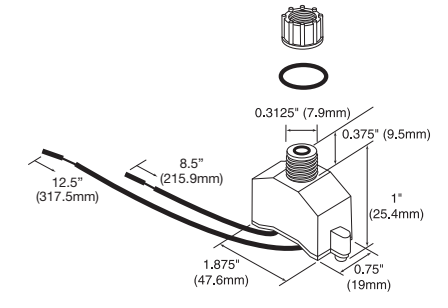

150° C Leads

### PTOSW7 Incandescent Dusk To Dawn Switch

- **Maximum Wattage:** 120V, Up to 60 Watts
- Electronic Circuit
- UL Recognized Component Photo Electric Switch
- Standard Packed 500 to a carton
- **Not for use with Fluorescent Lighting**

Style	Colors	Height	Width	Length	Lead Length
PTOSW7	Black	1.375"	.75"	1.875"	12.5/9"



03-024 (Clear)  
sold seperately



K005BR  
sold seperately

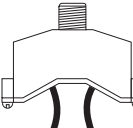

PTOSW7

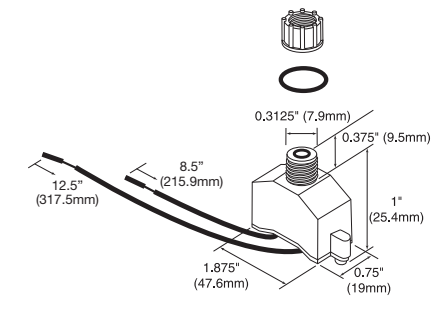

150° C Leads

**CAUTION:** Photocells are not designed for use with external power factor correcting capacitors. For your specific needs, please call Inter-Global on your application. Inter-Global cannot be responsible for non-Inter-Global equipment which is attached to or used in conjunction with the photocells and all such equipment is expressly excluded from Inter-Global's warranty.